

Alfred Jäger GmbH

SF-Elektromaschinenbau



KS4-21/40

High frequency spindle for
drilling, milling, grinding
and engraving



Technical data:

- Power output: 2,6 KW
- Rotation frequency speed: 5.000 - 40.000 rpm
- Ceramic hybrid precision ball bearings lubricated for life
- Pneumatic change of toolholder
- Clamping range: 1 - 10 mm
- Sealing air
- Rotation speed monitoring
- Temperature monitoring
- Liquid cooled
- Weight: 5,8 kg

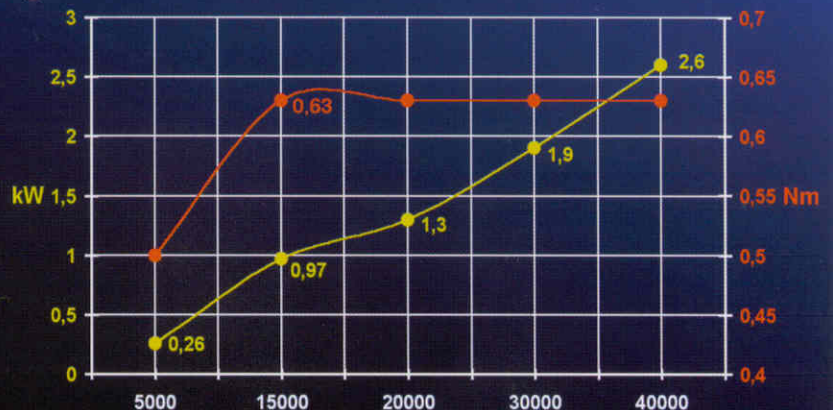



KS4-21/40

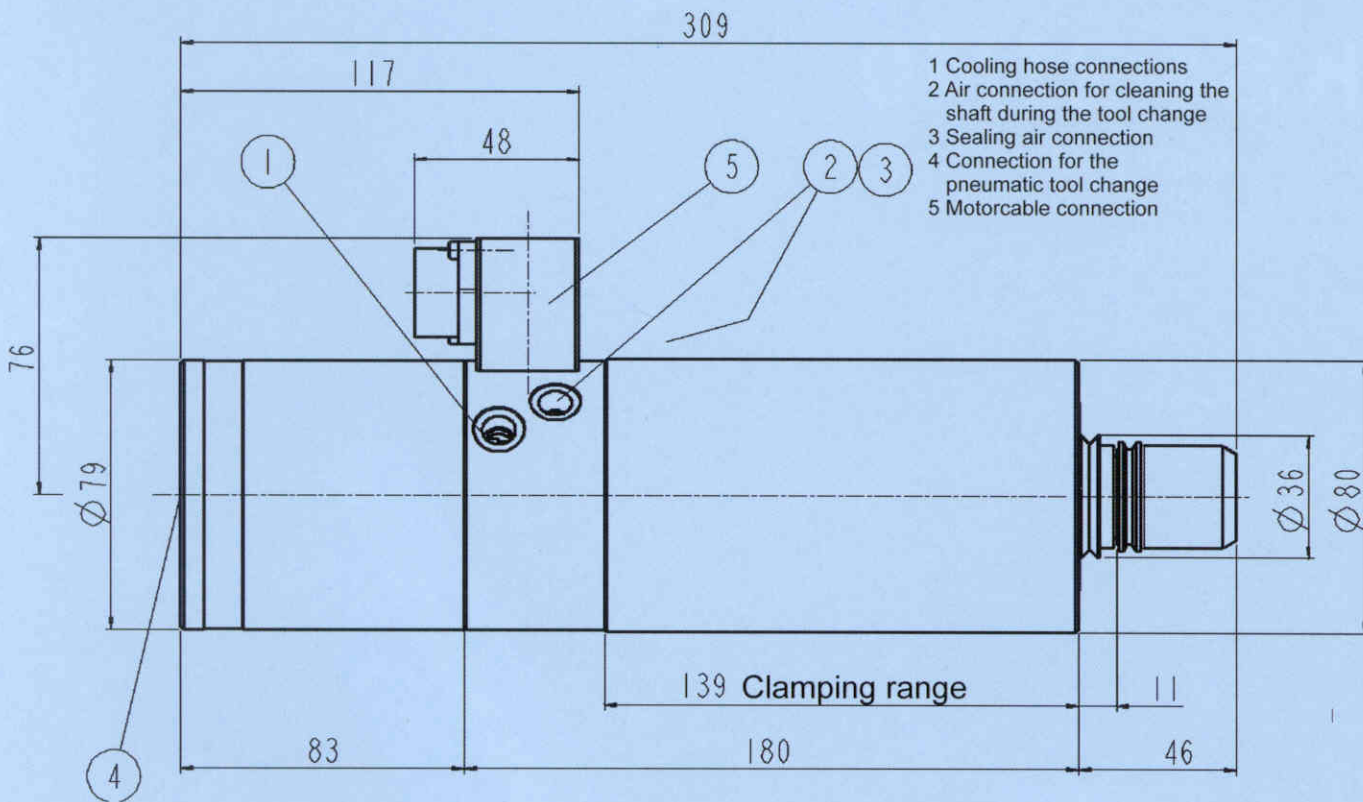

Accessories:

- Spindle bracket Ø 80 mm
- Toolholder
 - Toolholder WK 19-10 / 35 kpl. (incl. locknut)
 - Shrinking toolholder WK 19-10 ØE (3 - 10 mm)
- Collet type 10 D (1 - 10 mm)
- Tool-change pick-up station WS 35/30
- Operating line 07.4m (several length available)
 - 1 x Motorcable
 - 2 x Cooling hose
 - 1 x Sealing air hose
 - 1 x Hose for the pneumatic tool change
 - 1 x Air hose for cleaning the shaft during the toolchange
- Set of hose connectors 03
- System cabinet 49/3A/KKG1.2
 - Solid-state frequency converter 49/3A
 - Cooling unit KKG1.2
 - Pressure reducing valve for the sealing air
 - Option: with wheels
- System cabinet 49/3D/KKG1.2
 - Solid-state frequency converter 49/3D
 - Cooling unit KKG1.2
 - Pressure reducing valve for the sealing air
 - Option: with wheels
- Cable remote control
- Shrinking appliance

Update: 01/01

Alfred Jäger GmbH SF-Elektromaschinenbau, Siemensstraße 8, D-61239 Ober-Mörlen

Telefon: ++ 49 (0) 60 02 / 91 23 - 0

Telefax: ++ 49 (0) 60 02 / 91 23 - 40

Email: mail@alfredjaeger.de <http://www.alfredjaeger.de>